



Shower-Ware® 460HC Series

Apex Type 6 Two Station Handicapped Showers - Non ADA Compliant



463-HC-W

Fixture May Show Some Available Options

Please visit www.acorneng.com for most current specifications.

Apex Type 6 Two Station Handicapped Showers - Non ADA Compliant

-HC Handicapped Shower option includes a lever handle control valve, a flexshower with vacuum breaker, upper showerhead, a lever handle diverter valve, a recessed soap dish, and a 24" x 1-1/2" stainless steel grab bar. Unit does not fully conform with ADA requirements.

Housing is heavy gage, type 304 stainless steel with satin finish.

Supply Piping is "L" copper tubing and bronze or wrought copper fittings. Shower head riser and valve supply inlet piping may differ. Supply stub out is sized to provide adequate water to each head simultaneously. Piping is hydrostatically tested at 150 PSI.

Control Valve type is indicated by selected Apex model number however, -HC station is provided with a Safti-Trol hot and cold mixing valve with lever handle. All valves have replaceable cartridges which contain all wearing parts and are serviced from the face of the shower for easy maintenance. Valve is tamper-resistant with an easy to close mechanism and low leverage handle to protect the operating parts from excessive torque.

Shower Heads. A shower head on a five foot stainless steel hose (hand shower) is provided for seated bathers. A conventional fixed shower head is also provided at 6'-0" discharge height. Shower head is solid brass, triple chrome-plated and include built-in 2.5 GPM flow restrictor. The Acorn Logan Wizard Shower Head design provides self-cleaning with every use, and has an adjustable spray pattern from a coarse stream to a fine mist.

Mounting consists of anchoring "S" clips and "L" angle clips to wall. Then hang shower unit onto "S" clips and bolt bottom of unit to "L" clips. Connect supply lines.

Fasteners. Acorn furnishes all exposed tamper-resistant fasteners necessary to complete the on-site shower assembly; however, concealed wall fasteners or anchor shields are not furnished.

Privacy Compartments. Disabled bathers understandably should be given privacy while bathing. This suggests providing a separate cubicle not in the group shower room.

GUIDE SPECIFICATION

Provide and install Acorn Apex Two Station Handicapped Shower (specify model numbers and options). Housing shall be 16 gage, type 304 stainless steel with satin finish. Shower shall be factory pre-piped and hydrostatically factory tested to 150 PSI. Fixture shall be furnished with a lever handle control valve, a flexshower with vacuum breaker, upper showerhead, a lever handle diverter valve, a recessed soap dish and a 24" x 1-1/2" stainless steel grab bar. Unit does not fully conform with ADA requirements. Installation shall be made in accordance with manufacturer's recommendations and details.

Shower-Ware®: 460HC Apex Type 6 Two Station Handicapped Showers - Non ADA Compliant



Shower Head Discharge Height (Not Part of Model Number)

__6'-0"__5'-6"__5'-0"__Other (Specify) _____

MODEL NUMBER AND OPTIONS SELECTION

SERIES (Must Specify)

4 - Apex

TYPE (Must Specify)

-6 - Two Station Handicapped Showers

VALVE (Must Specify)

- 0 - HC -Electronic Valves, Single-Temp Metering
- 1 - HC - Flo-Cloz, H & C
- 2 - HC - Safti-Trol, H & C Pressure Balancing
- 3 - HC- Safti-Therm, H & C Temperature Balancing
- 4 - HC - Single-Trol, H & C Mixing
- 5 - HC -Flo-Cloz, Single Temperature
- 6 - HC - Air-Control, Single Temperature Metering
- 7 - HC - Meter-Matic, Single Temperature Metering
- 9 - HC - Without Valves (Remote Control)

ELECTRONIC VALVE SELECTION (Refer to Valves Section for Submittal Data)

- EVS1 Electronic Valve System - Single Temp
- MVC1 Time-Trol - Single Temp

SUPPLY (Must Specify)

- T Top
- W Wall

HC LOCATION (Must Specify)

__ L.H. Side __ R.H. Side

Product Options

- BAT Battery Operated (-MVC1)
- BS Built-in Liquid Soap System
- CI Cycle Interrupt
- CSH Conical Showerhead
- D Soap Dish
- DS Diana Circular Privacy (See Diana Privacy Tab)
- EG Enviro-Glaze Color, Specify _____
- F Flow Control 2.0 GPM
- FG 14 Gage Material Construction
- FH Fixed Head in Lieu of Hand Shower
- G Individual Stops
- GG Unit Shutoff Valve
- GX Individual Check stops
- H Hand Volume Control
- HL Hi-Lo Mounting Brackets (For Handshower)
- K Allen Key Volume Control
- LGB Less Grab Bar
- LRD Less Recessed Soap Dish
- MS Modular Privacy Compartments (See Diana Privacy Tab)
- MSH Multi-Stream Shower Head
- P Penal Shower Head
- PBH Hemispherical Pushbutton
- PO Piston-Operated Safti-Trol Valve
- QD Quick Disconnect for Hand Shower
- RD Recessed Soap Dish
- SB 24" Slide Bar (For -FX Hand Shower)
- SC Supply Cover, Ceiling Height _____
- SLPB Sloping Bottom
- SLPT Sloping Top
- TF Transformer
- WH Wide Housing
- WS Without Showerhead
- Y Universal Ball Joint
- YY Lockable Universal Ball Joint
- Z Up-Down Ball Joint
- ZZ Lockable Up-Down Ball Joint

Please visit www.acorneng.com for most current specifications.

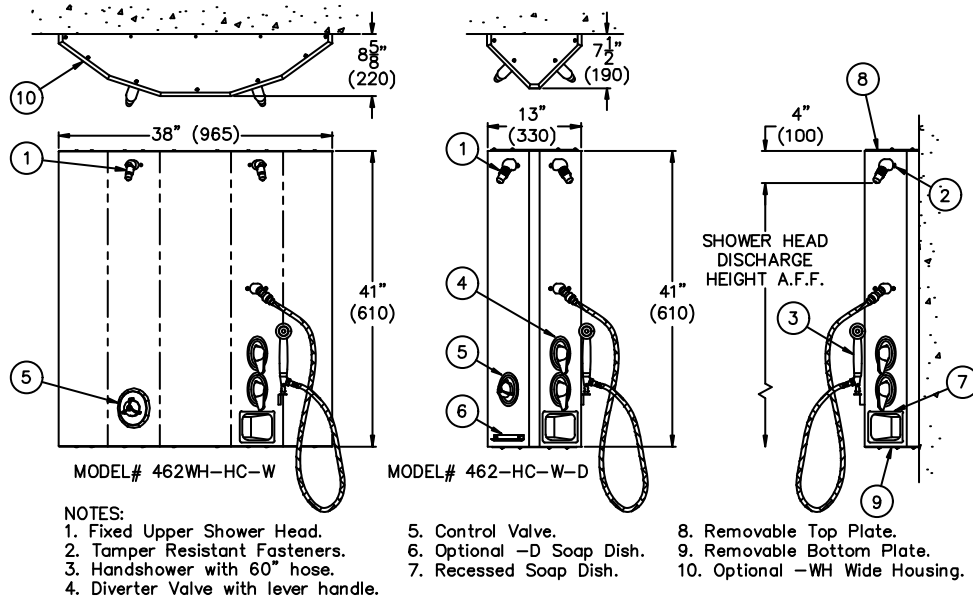

<p>Important: Installation instructions and current rough-in are furnished with each fixture. Do not rough in without certified dimensions. Dimensions are subject to manufacturer's tolerance of plus or minus 1/4" and change without notice. Acorn assumes no responsibility for use of void or superseded data. © Copyright 2006 Acorn Engineering Company</p>	
<p style="text-align: center;">Selection Summary</p> <p>Model No. & Option _____</p> <p>Quantity _____</p>	<p style="text-align: center;">Approved for Manufacturing</p> <p>Company _____ Title _____</p> <p>Signature _____ Date _____</p>